

Fig No: B924 L/T Reduced Bore
1/2"~ 4" DN15 ~ DN100



Features :

- Investment Cast Components
- Reduced Bore
- Blow - out - proof stem design , Bottom entry stem
- Valve design allows 360 degree rotation, positive location is available at 90 degree increments
- ISO 5211 Mounting pad by the valve locking device
- For Food , General Chemical and Industrial application

Standard Compliance :

- ASTM ASME B16.34 API 608 API 598
- EN 10213 EN 12516 EN 12266
- BS21(BSPP) BS21(BSPT)
- ISO 228-1 ISO 7-1 ISO 5211 DIN 2999

Specifications :

- End connection : Threaded end
- Working Pressure : 1000 psi / 63 Bar (CWP)
- Temperature Range : -4 to 356°F (-20 to 180°C)
- Pressure test according to API 598 or EN 12266

MATERIALS LIST

ITEM	PARTS	MATERIAL	Qty
1	BODY	ASTM A351 GR.CF8M	1
4	BALL	ASTM A351 GR.CF8M	1
5	STEM	S.S. 316	1
9	CAP	ASTM A351 GR.CF8M	4
11	GASKET	PTFE	4
12	SEAT	PTFE	4
13	THRUST WASHER	PTFE	1
14	STEM PACKING	PTFE	1SET
15	RING	S.S. 304	1
19	HANDLE	S.S. 304	1
20	NUT	S.S. 304	1
22	NUT	S.S. 304	1
24	NUT	S.S. 304	1
29	BEVEL WASHER	S.S. 301	2
30	TAB WASHER	S.S. 304	1
31	O-RING	VITON	1
33	STOP PIN	S.S. 304	1
35	BOLT	S.S. 304	16
36	SPRING WASHER	S.S. 304	16

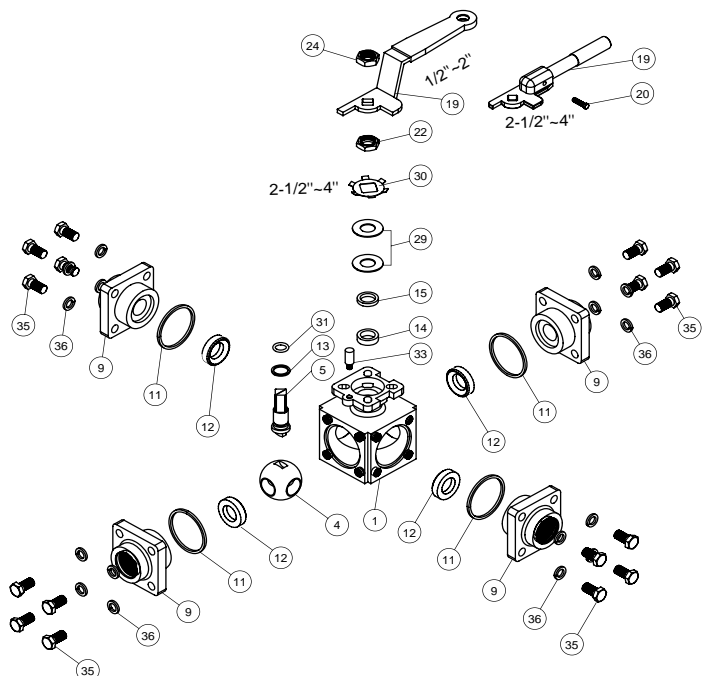
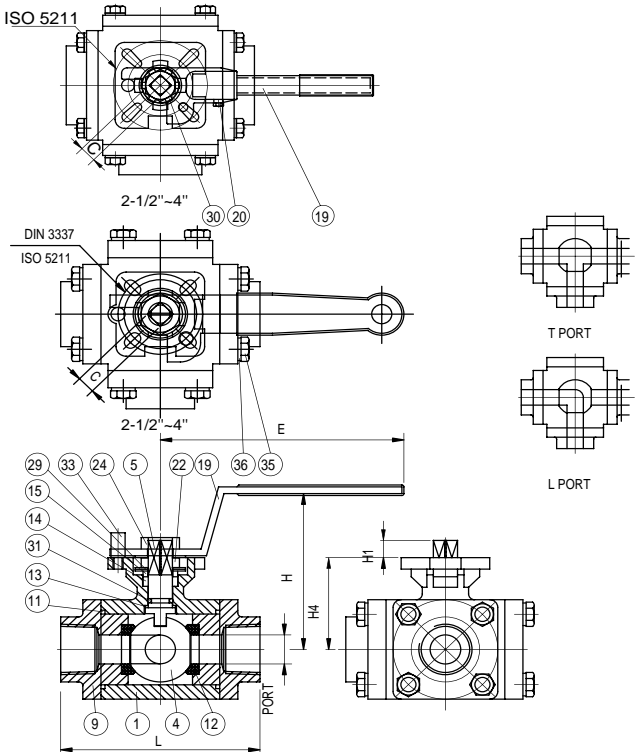

DIMENSIONS

unit:mm

SIZE	PORT	L	E	H	H1	H4	C	ISO-5211
1/2"	11.2	100.0	121.0	78.0	9.0	44.5	9.0	F03 / F04
3/4"	15.2	105.0	121.0	82.0	9.0	48.0	9.0	F03 / F04
1"	20.2	124.0	137.0	89.0	11.0	59.0	11.0	F04 / F05
1-1/2"	32.2	155.0	182.0	110.0	14.0	72.0	14.0	F05 / F07
2"	40.3	184.0	182.0	114.7	14.0	82.0	14.0	F05 / F07
2-1/2"	50.8	217.0	370.0	110.0	17.0	100.0	17.0	F07 / F10
3"	65.4	252.0	400.0	134.0	23.0	125.5	22.0	F10 / F12
4"	80.0	282.0	400.0	140.0	23.0	132.5	22.0	F10 / F12